

# ENERGIZER CR2430

## Lithium Coin



### Industry Standard Dimensions

mm (inches)



This Battery has Underwriters Laboratories component Recognition

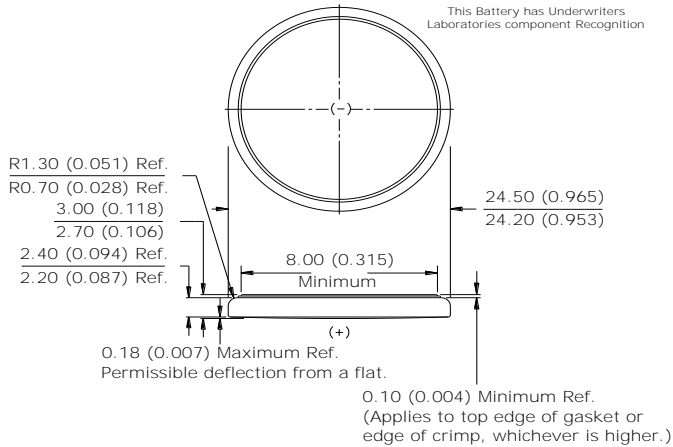

### Simulated Application test

Typical Performance at 21°C (70°F)

Schedule:	Typical Drains: at 2.9V (mA)	Load (ohms)	Cutoff 2.0V (hours)
Continuous	0.29	10,000	1,000

### Typical Discharge Characteristics

Load: 10K ohms - Continuous  
Typical Drain @ 2.9V: 0.29 mA

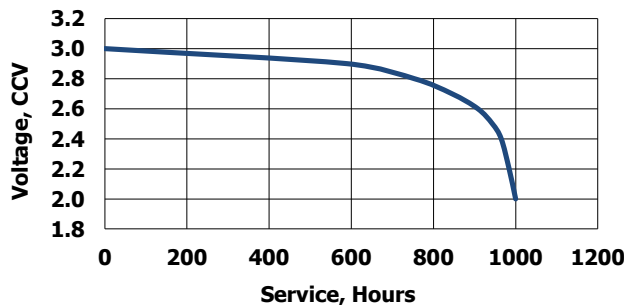

### Internal Resistance Characteristics

Pulse Test at 21°C (70°F)

**Bkgnd Drain:** Continuous  
10K ohms  
0.29 mA @ 2.9V

**Pulse Drain:** 2 seconds X 12 times/day  
300 ohms  
9.3 mA @ 2.7V

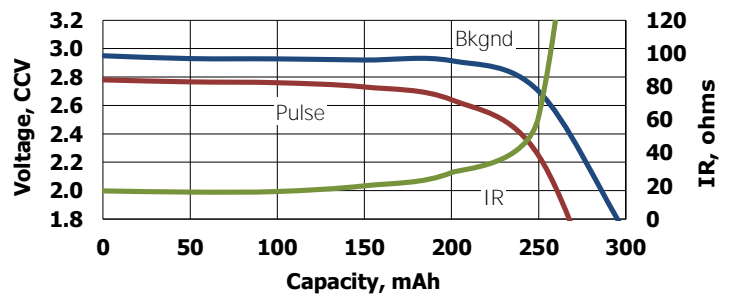

### Important Notice

This datasheet contains typical information specific to products manufactured at the time of its publication.  
©Energizer Holdings, Inc. - Contents herein do not constitute a warranty.

### Safety:



**(1) KEEP OUT OF REACH OF CHILDREN.** Swallowing may lead to serious injury or death in as little as 2 hours due to chemical burns and potential perforation of the esophagus. **Immediately see doctor; have doctor phone (202) 625-3333.**

**(2) Battery compartment design.** To prevent children from removing batteries, battery compartments should be designed with one of the following methods: a) a tool such as screwdriver or coin is required to open battery compartment or b) the battery compartment door/cover requires the application of a minimum of two independent and simultaneous movements of the securing mechanism to open by hand. Screws should remain captive with the battery door or cover.